

Hovex De-Sanding Cyclone

HCP 50 / 100 / 150 *)

*) Indicates inlet diameter of cyclone



High wear resistance:

- Full stainless steel construction
- Ceramic cyclone body
- Minimum of maintenance & service
- Long lifetime

Tailor made:

- Full capacity flexibility
- Easy installation

Automatic solids discharge

Excellent solids-fluids separation

- No starch loss
- Less wear down stream

Broad range of application:

- Effective separation for various suspensions containing sand or other coarse particles

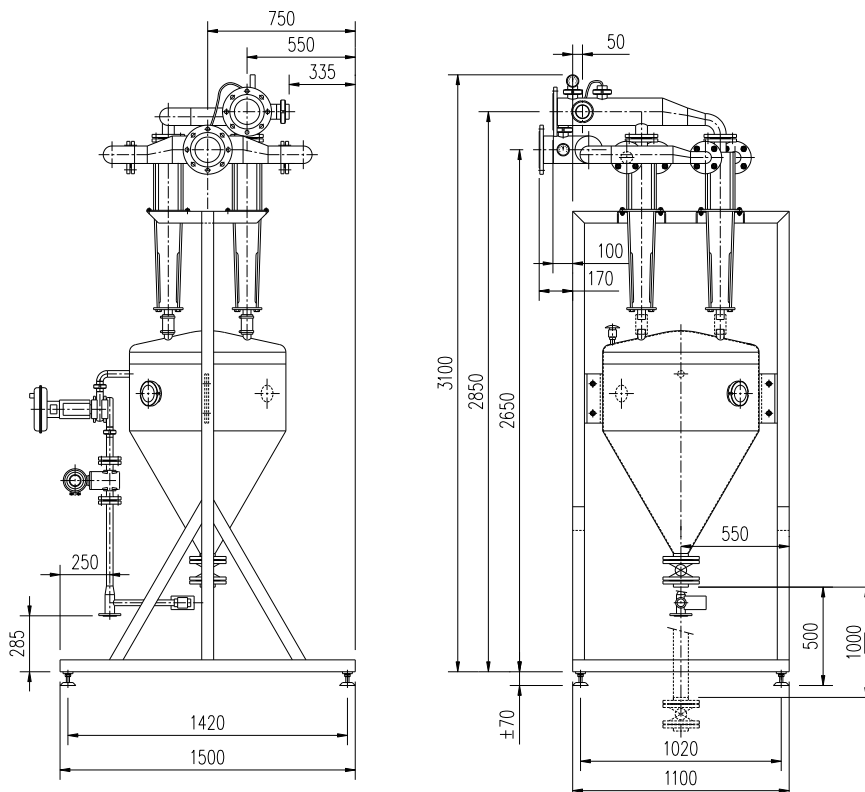

	HCP 50	HCP 100	HCP 150
Feed capacity (m3/hr)	7	15	25